



**VACUUM**  
BRANDS LTD

call 09 520 1115  
for more info  
Simplifying Choice with Knowledge



## Annual Product Manual

Welding fume extractor & Industrial dust collector catalogue

Converge New Technology  
Enjoy Fresh Air





## ABOUT US

VILLO ENVIRONMENTAL PROTECTION INC. is one of the leading manufacturers specializing in making of industrial environmental friendly equipment. Our company is an enterprise with the integration of R & D, manufacture, sales, service and training. Through years of efforts build our brand "VILLO" with series of products, including industrial vacuum cleaner, dust collector, welding fume purifier and so on. It has been putting constantly effort into the environmental friendly revolution of modern industry.

Our vision: To be the most professional supplier of industrial cleaning equipment

Our mission: Creating value for global industrial enterprises

We have been dedicating to R & D and innovation. At present, our product line cover 100 models with 30 series which range from mobile series, stationary series, solid-liquid separation series, and central dust collector system. We provide wide range solutions that covering automobile manufacturing, shipbuilding, electric power, petrochemical, textile, food, pharmaceutical, electronics, construction, machinery industry and so on. We are a reliable industrial cleaning equipment suppliers for global industry enterprises, and persevering to offer a comprehensive and professional consultation, fast and efficient services.

In recent year, our company has passed the certification of "National High-tech Enterprise", ISO9000 and CE. "Dedicated, Professional and Innovative" is Our business philosophy. We are focus on creating customer's value, making our team more professional, pursuing innovation and outstanding. We will provide people with its top products and services to create an environmental friendly and energy-saving society.



## AWARDS & CERTIFICATES

ENVIRONMENTAL PROTECTION INC.

### Go Through Market Testing, Achieve Infinite Value.

Villo's success heads from making all-out efforts to our customer and excellently pursuing high quality on products.

In 2005, Villo's all products were approved by CE, and meet European standard;

In 2009, Villo got ISO9001 quality management system certification

In 2010, Villo won the honorary title of "Enterprise of Good Creditworthiness" in Guangdong Province.

In 2011, Villo was approved by "Certificate of private technology enterprises"

In 2012, Villo won the certificate of "National High-tech Enterprise"

In 2013, Villo won the honorary title of "Enterprise of Good Creditworthiness" for 3years continuously

In 2014, Villo jointed ISSA and became a VIP member.



Villo won the certificate of "National High-tech Enterprise"



Villo is approved by "Certificate of private technology enterprises"



Villo won the honorary title of "Enterprise of Good Creditworthiness" In Guangdong Province



Villo won the honorary title of "Enterprise of Good Creditworthiness" for 3years continuously



Villo jointed ISSA and became a VIP member



Villo's all products were approved by CE, and meet European standard



Villo got ISO9001 quality management system certification

## CONTENTS

ENVIRONMENTAL PROTECTION INC.

P01-02	VHX Series Plate and Frame Type Soldering Fume Extractor	P11-12	VH-T Series Filter Cartridge Type Welding Smoke Purifier
P03-04	VHT Series Filter Cartridge Type Soldering Fume Extractor	P13-14	VH-B Series Wall Mounting Type Welding Smoke Purifier
P05-06	VHJ-B Series Plate and Frame Type Welding Smoke Purifier	P15-16	VP Series Unibody Type Welding and Grinding Table
P07-08	VHJ-T Series Filter Cartridge Type Welding Smoke Purifier	P17-18	VJF Series pulse jet cleaning type industrial dust collector
P09-10	VH-B Series Plate and Frame Type Welding Smoke Purifier	P19-20	VJ Series Simple Type Industrial Dust Collector



## VHX Series Plate and Frame Type Soldering Fume Extractor

### APPLICATION FILED:

- Apply to single phase voltage working condition;
- Suitable for the fume and dust disposal in the soldering process of the circuit boards and electronic industry ;
- Suitable for the smoke purification during the process of the soldering, wave soldering, laser welding, sculpture, etc.

### SPECIALTY:

#### 1、HEPA FILTER:

1.1 HEPA filter unit= the early effect filter +in effect filter+ high efficiency filters +activated carbon air filter . It is unibody construction and can filtering 0.1 micron dust, the filter rating is up to 99.99% for the 0.3~0.5 micron dust, which can reach the indoor emission standard .



#### 2、360° Rotatable Suction Arm

2.1 Suction arm pipe is composed of various movable joints, can be arbitrarily curved, parks, the universal suction arm can hover freely at 360 degrees.



#### 3、Adjustable Airflow

3.1 PWM speed control equipped, the customer can adjust the airflow according to the dust amount, practical, convenient, Eco-friendly and energy saving.



### STRUCTURE DIAGRAM:



### APPLICATION:



Lace knitting machines supported vacuuming



PCB soldering fume extraction



Tin soldering supported fume extraction

### TECHNICAL PARAMETERS :

Model	VHX-15J	VHX-15	VHX-15D
Voltage ( V/Hz )	220/50	220/50	220/50
Power ( W )	135	135	135
Max negative pressure (Pa)	2500	3200	3200
Max Air Flow (m <sup>3</sup> /h)	200	200	200
Noise dB(A)	63 ± 2	63 ± 2	63 ± 2
Inlet diameter (mm)	1*Ø50	1*Ø50	2*Ø50
Filtering area ( m <sup>2</sup> )		1.8	
Filter rating (L)	>90%	>90%	>90%
Dimensions (mm)		320*300*460	
Net weight ( kg )	20	20	22
Motor protection degree		IP54	



Application

- Soldering operation
- Medical moxibustion
- Electrostatic dust elimination
- Electronic component dust elimination
- Laser marking operation

VHT Series Filter Cartridge Type Soldering Fume Extractor

APPLICATION FILED:

- Apply to single phase voltage working condition
- Suitable for the fume and dust disposal in the soldering process of the circuit boards and electronic industry .
- Suitable for the smoke purification during the process of the soldering, wave soldering, laser welding, sculpture, etc
- VHT-C can apply to the electrostatic precipitation for the small work-piece surface.

SPECIALTY:

1、HEPA Filter:

1.1 Installed with HEPA filter cartridge which is imported from TORAY, Japan. It can filtering 0.3 micron dust, and the filter rating is up to 99.99%

2.2 Convenient dust cleaning structure.



2、360° Rotatable Suction Arm

2.1 Suction arm pipe is composed of various movable joints, can be arbitrarily curved, parks, the universal suction arm can hover freely at 360 degrees.



3、Electrostatic elimination

3.1 VHT-C series equipped with the Ion wind snakes ,which can remove the work-piece electrostatic dust effectively.



STRUCTURE DIAGRAM:

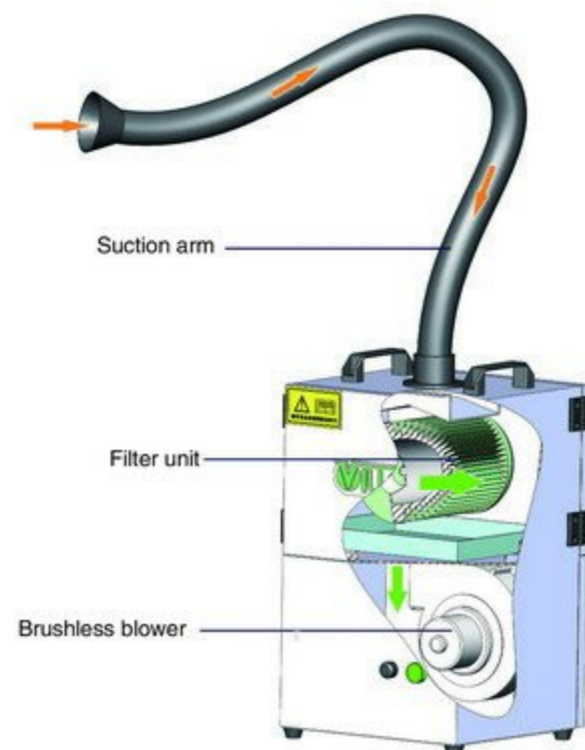

APPLICATION:



small-sized transformer welding supported fume extractor



laser marking operation supported fume extractor



electrostatic dust collection for the electronic components processing

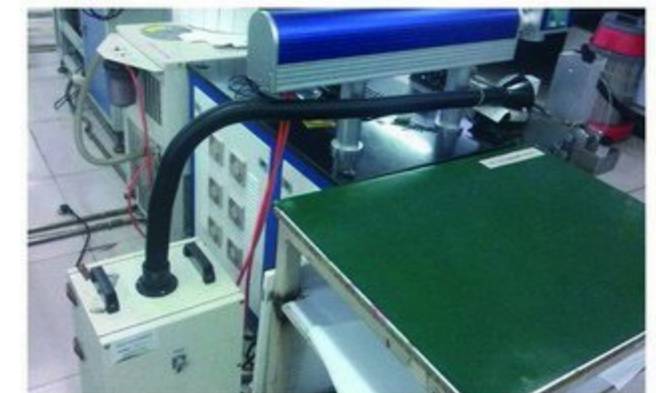

laser printer supported fume extractor

TECHNICAL PARAMETERS:

Model	VHT-15S	VHT-15C
Voltage ( V/Hz )	220/50	220/50
Power ( W )	135	135
Max negative pressure (Pa)	3200	3200
Max Air Flow ( m³/h )	220	220
Noise dB(A)	63 ± 2	63 ± 2
Inlet diameter ( mm )	1'Ø50	1'Ø50
Filtering area ( m² )	1.8	1.8
Filter rating ( L )	>90%	>90%
Dimensions ( mm )	320*300*520	320*300*520
Net weight ( kg )	20	23
Motor protection degree	IP54	IP54



- Welding operation
- Metal processing operations
- Grinding operation
- Spraying operation

## VHJ-B Series Plate and Frame Type Welding Smoke Purifier

### APPLICATION FILED:

- Apply to welding, cutting, grinding, and other smoke purification fields .
- Suitable for movable welding place, polluted welding place or other similar working conditions .
- Suitable for smoke purification of manual arc welding; gas shielded arc welding, argon arc welding and other welding purification occasions .

### SPECIALTY:

#### 1、HEPA Filter:

1.1 HEPA filter unit= the early effect filter +in effect filter+ high efficiency filters +activated carbon air filter . It is separation structure design and can filtering 0.1 micron dust, the filter rating is up to 99.99% for the 0.3-0.5 micron dust, which can reach the indoor emission standard .



VHJ-B Series

### STRUCTURE DIAGRAM:

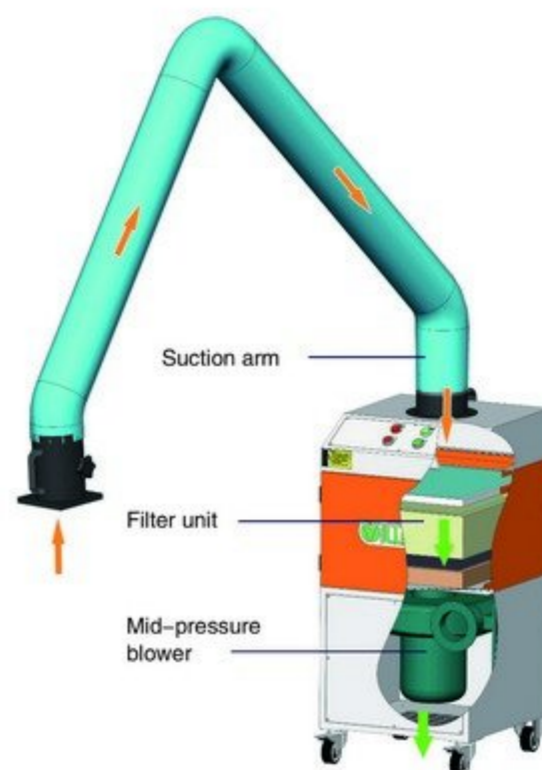

#### 2、360° Rotatable Suction Arm

2.1 Suction arm pipe is composed of rotating arm and expansion pipe, can be arbitrarily curved, parks, the universal suction arm can hover freely at 360 degrees.



### APPLICATION:



Sheet metal processing workshop supported fume extraction



welding workshop supported fume extraction



Sheet metal processing workshop supported fume extraction



welding workshop supported fume extraction

### TECHNICAL PARAMETERS:

Model	VHJ-110B
Voltage ( V/Hz )	380/50
Power (KW)	1.1
Max negative pressure (Pa)	2180
Max Air Flow ( m <sup>3</sup> /h)	1500
Noise dB(A)	75 ± 2
Inlet diameter ( mm)	1*Ø150
Filtering area ( m <sup>2</sup> )	6
Filter rating (L)	>99%
Dimensions ( mm)	500*530*1060
Net weight ( kg )	110



- Welding operation
- Metal processing operations
- Grinding operation
- Spraying operation

## VHJ-T Series Filter Cartridge Type Welding Smoke Purifier

### APPLICATION FILED:

- Apply to welding, cutting, grinding, and other smoke purification fields .
- Suitable for movable welding place, polluted welding place or other similar working conditions .
- Suitable for smoke purification of manual arc welding: gas shielded arc welding, argon arc welding and other welding purification occasions .

### SPECIALTY:

#### 1、HEPA Filter:

- 1.1 Installed with HEPA filter cartridge which is imported from TORAY, Japan. It can filtering 0.3 micron dust, and the filter rating is up to 99.99%
- 1.2 Convenient dust cleaning structure ,VHJ-T series doesn't have dust cleaning device .
- 1.3 VHJ-TS series have manual dust cleaning device .



VHJ-T / VHJ-TS Series

### STRUCTURE DIAGRAM:

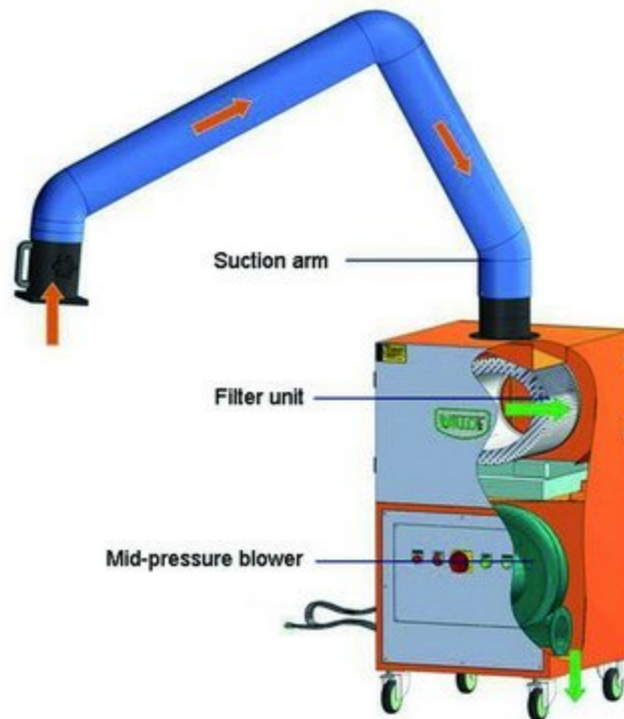

#### 2、360° Rotatable Suction Arm

- 2.1 Suction arm pipe is composed of rotating arm and expansion pipe, can be arbitrarily curved, parks, the universal suction arm can hover freely at 360 degrees.



### APPLICATION:



volume production for the VHJ-110T

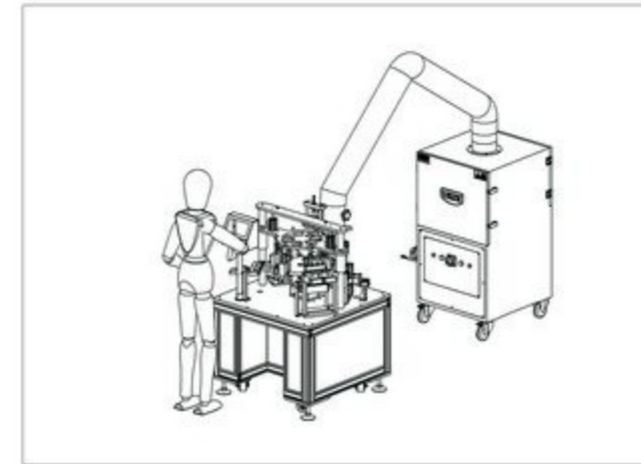

Apollo Of Smidakh supported fume extraction



Lithium battery automatic touch welding machine supported fume extraction

### TECHNICAL PARAMETERS:

Model	VHJ-110T	VHJ-220T
	VHJ-110TS	VHJ-220TS
Voltage ( V/Hz )	380/50	
Power (KW)	1.1	2.2
Max negative pressure (Pa)	2180	2500
Max Air Flow (m³/h)	1500	1800
Noise dB(A)	75 ± 2	75 ± 2
Inlet diameter (mm)	1"Ø 150	2"Ø 150
Filtering area ( m² )	8	11
Filter rating (L)	>99%	>99%
Dimensions (mm)	580*620*1150	700*750*1250
Net weight ( kg )	105	130



- Application**
- Welding operation
  - Metal processing operations
  - Grinding operation
  - Spraying operation
  - Peculiar smell contain powder operation

## VH-B Series Plate and Frame Type Welding Smoke Purifier

### APPLICATION FILED:

- Apply to welding, cutting, grinding, and other smoke purification fields .
- Suitable for movable welding place, polluted welding place or other similar working conditions .
- Suitable for smoke purification of manual arc welding; gas shielded arc welding, argon arc welding and other welding purification occasions .

### SPECIALTY:

#### 1、HEPA Filter:

- 1.1 Early effect filter : Aluminum alloy frame and metal mesh, which can filtering welding burnish sparks and large dust particles.
- 1.2 In effect filter: Folding frame air filter, can be washed and reused
- 1.3 High efficiency filters: Consist of Glass fiber or nano materials, can filtering 0.1 micron dust, the filter rating is up to 99.99% .
- 1.4 Activated carbon air filter: Remove the bad smell effectively .

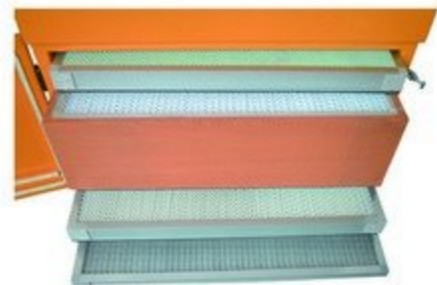

#### 2、360° Rotatable Suction Arm

- 2.1 Suction arm pipe is composed of rotating arm and expansion pipe, can be arbitrarily curved, parks, the universal suction arm can hover freely at 360 degrees.



VH-B Series

### STRUCTURE DIAGRAM:

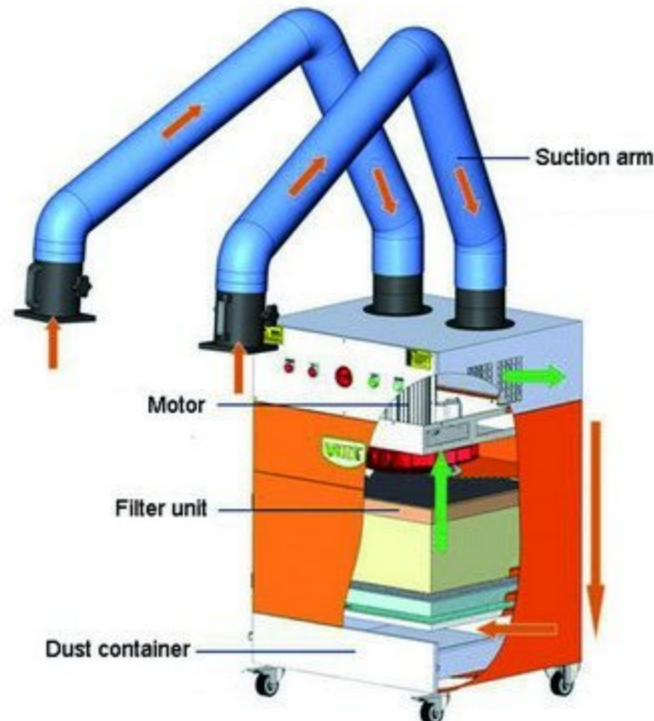

### APPLICATION:



Fume extraction for the metal piece cutting



VH-B testing operation



Fume extraction for the metal piece welding

### TECHNICAL PARAMETERS:

Model	VH-150B	VH-220B
Voltage ( V/Hz )	380/50	
Power (KW)	1.5	2.2
Max negative pressure (Pa)	1200	1800
Max Air Flow ( m³/h)	1800	2800
Noise dB(A)	75 ± 2	75 ± 2
Inlet diameter (mm)	1'Ø 150	2'Ø 150
Filtering area ( m² )	12	18
Filter rating (L)	>99%	>99%
Dimensions (mm)	610*540*1200	700*750*1200
Net weight ( kg )	130	170



## VH-T Series Filter Cartridge Type Welding Smoke Purifier

### APPLICATION FILED:

- Apply to welding, cutting, grinding, and other smoke purification fields .
- Suitable for movable welding place, polluted welding place or other similar working conditions .
- Suitable for smoke purification of manual arc welding; gas shielded arc welding, argon arc welding and other welding purification occasions .

### SPECIALTY:

#### 1、HEPA Filter:

- 1.1 Installed with HEPA filter cartridge which is imported from TORAY, Japan. It can filtering 0.3 micron dust, and the filter rating is up to 99.99%
- 1.2 Pulse-jet cleaning system .



#### 2、360° Rotatable Suction Arm

- 2.1 Suction arm pipe is composed of rotating arm and expansion pipe, can be arbitrarily curved, parks, the universal suction arm can hover freely at 360 degrees.



VH-T SERIES

### STRUCTURE DIAGRAM:

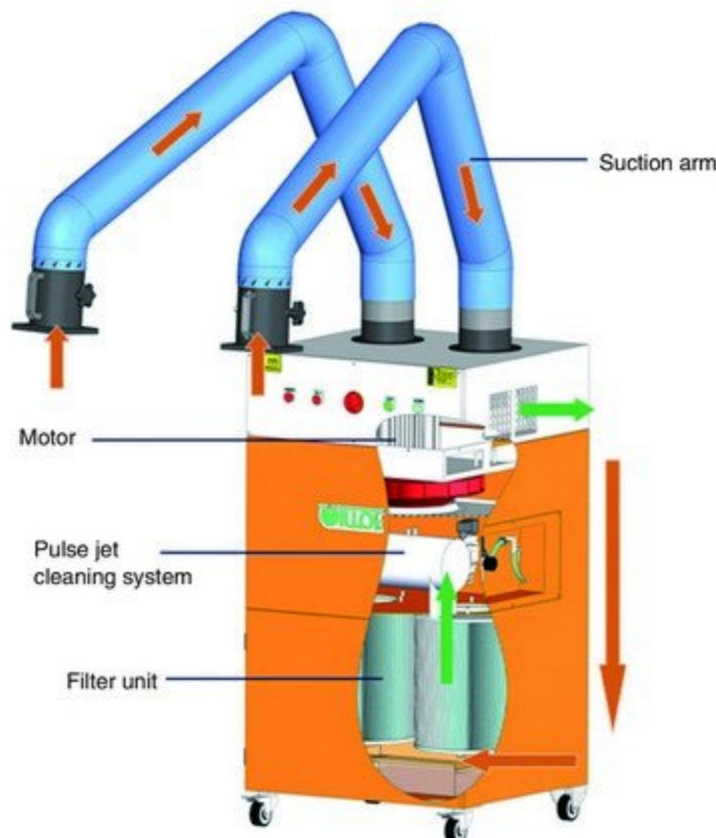

### APPLICATION:

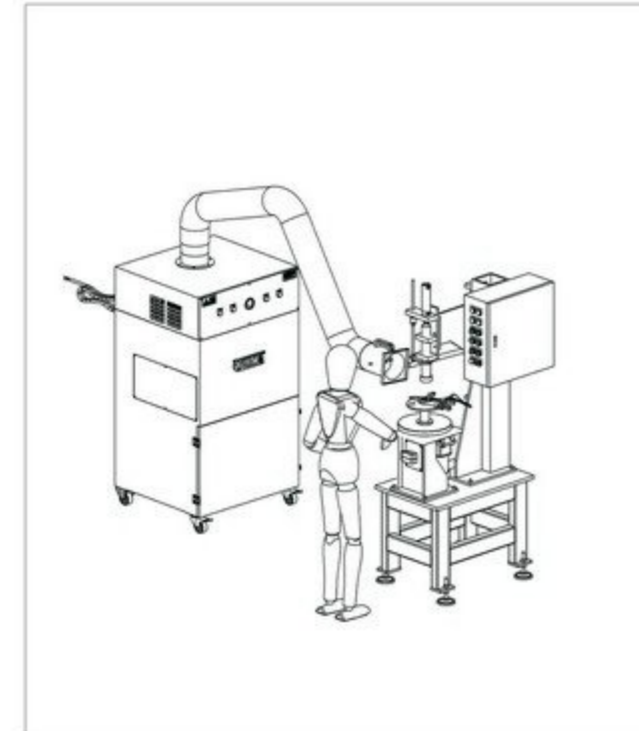

Auto rotation welding machine supported fume extraction

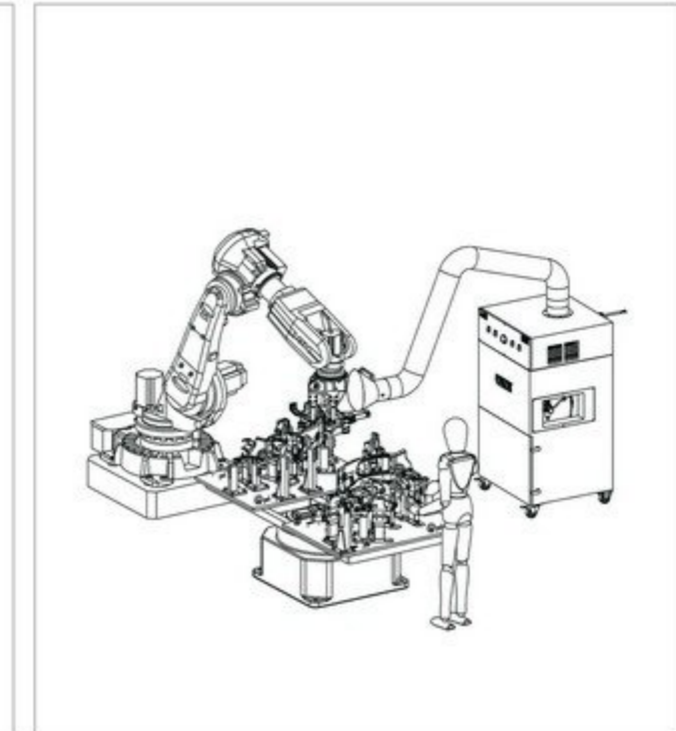

Automobile parts welding manipulator supported fume extraction

### TECHNICAL PARAMETERS:

Model	VH-150T	VH-220T
Voltage ( V/Hz )	380/50	
Power (KW)	1.5	2.2
Max negative pressure (Pa)	1780	2000
Max Air Flow (m <sup>3</sup> /h)	1800	2800
Noise dB(A)	75 ± 2	75 ± 2
Inlet diameter (mm)	1" Ø 150	2" Ø 150
Filtering area ( m <sup>2</sup> )	10	15
Filter rating (L)	>99%	>99%
Dimensions (mm)	700*750*1400	700*750*1600
Net weight ( kg )	150	210





- Application**
- Welding operation
  - Metal processing operations
  - Grinding operation
  - Spraying operation
  - Huge amount of powder operation

## VH-B Series Wall Mounting Type Welding Smoke Purifier

### APPLICATION FILED:

- Apply to welding, cutting, grinding, and other smoke purification fields .
- Suitable for movable welding place, polluted welding place or other similar working conditions .
- Suitable for smoke purification of manual arc welding; gas shielded arc welding, argon arc welding and other welding purification occasions .

### SPECIALTY:

#### 1、HEPA Filter:

- 1.1 Early effect filter : Aluminum alloy frame and metal mesh, which can filtering welding burnish sparks and large dust particles;
- 1.2 In effect filter: Folding frame air filter, can be washed and reused;
- 1.3 High efficiency filters: Consist of Glass fiber or nano materials, can filtering 0.1 micron dust, the filter rating is up to 99.99% .



#### 2、360° Rotatable Suction Arm

- 2.1 Suction arm pipe is composed of rotating arm and expansion pipe, can be arbitrarily curved, parks, the universal suction arm can hover freely at 360 degrees.



VHW-B Series

### STRUCTURE DIAGRAM:

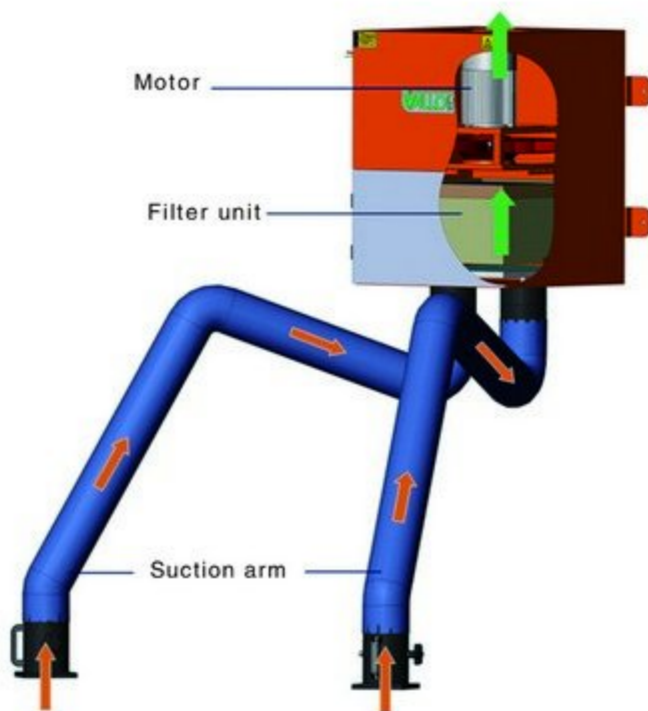

### APPLICATION:

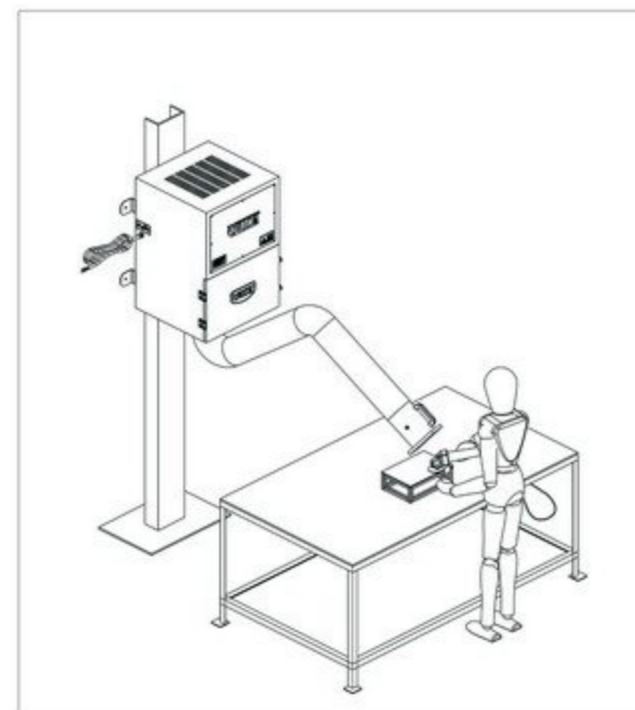

work table grinding supported fume extraction

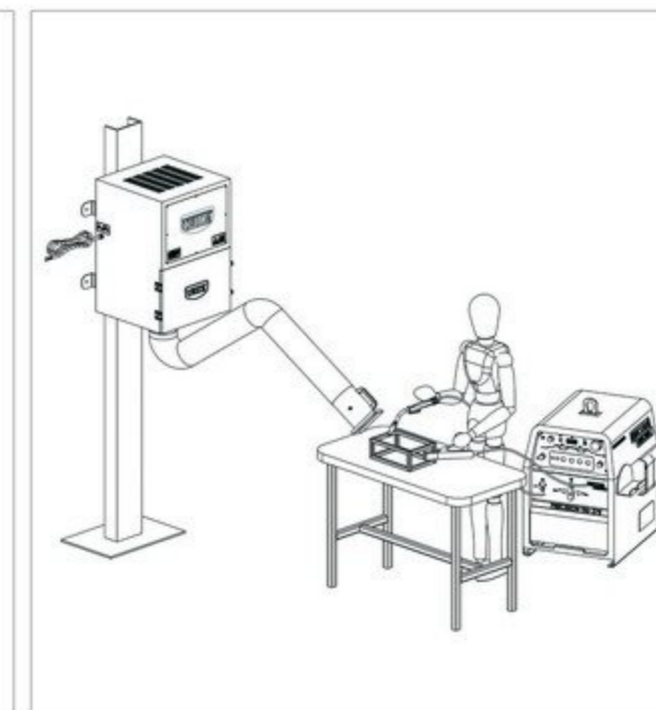

small work piece welding fume extraction

### TECHNICAL PARAMETERS:

Model	VHW-150B	VHW-220B
Voltage ( V/Hz )	380/50	
Power (KW)	1.5	2.2
Max negative pressure (Pa)	1200	1800
Max Air Flow (m <sup>3</sup> /h)	1800	2800
Noise dB(A)	75 ± 2	75 ± 2
Inlet diameter (mm)	1"Ø 150	2"Ø 150
Filtering area ( m <sup>2</sup> )	12	18
Filter rating (L)	>99%	>99%
Dimensions (mm)	610*540*1200	700*750*1400
Net weight ( kg )	130	170



## VP Series Unibody Type Welding and Grinding Table

### APPLICATION FILED:

- Apply to welding, cutting, grinding, and other unibody type smoke purification fields .

### SPECIALTY:

#### 1、HEPA Filter:

- 1.1 Installed with HEPA filter cartridge which is imported from TORAY, Japan. It can filtering 0.3 micron dust, and the filter rating is up to 99.99%
- 1.2 Pulse jet cleaning system, and easy to replace the filter cartridge.



#### 2、High quality humanized design

- 2.1 304 stainless steel work table, impact and corrosion resistance;
- 2.2 Daylight lamp installed ,convenient for the night job;
- 2.3 220V wiring board equipped ,easy to plug in the grinding machine.



VP Series

### STRUCTURE DIAGRAM:

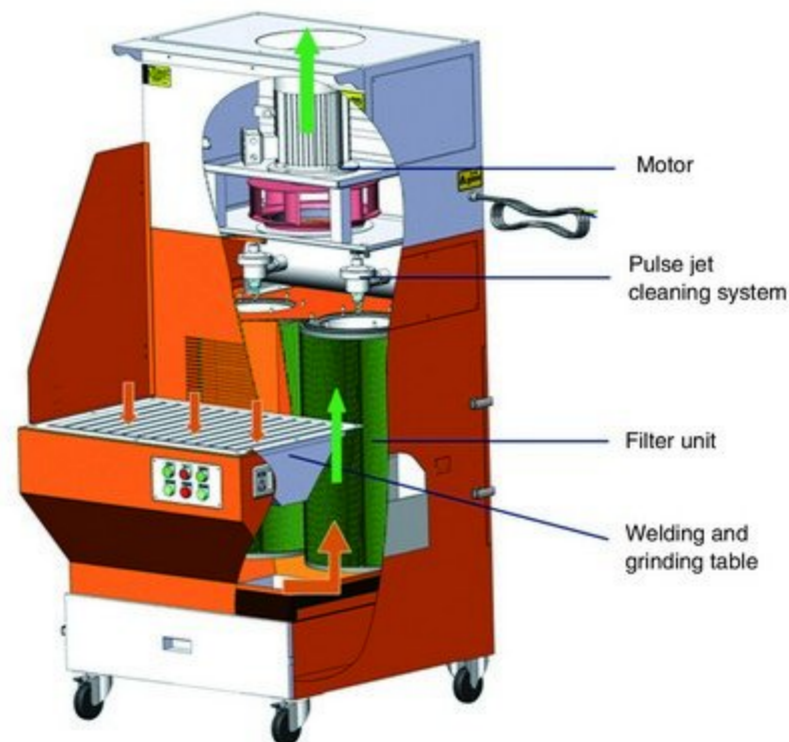

### APPLICATION:



Field application



Single-step workpiece grinding



Big work piece welding fume extraction



Small work piece welding fume extraction

### TECHNICAL PARAMETERS:

Model	VP-300
Voltage ( V/Hz )	Three phase 380V/50hz
Power (KW)	3.0
Max air pressure (Pa)	1800
Max air flow (m <sup>3</sup> /h)	3600
Noise dB(A)	75 ± 2
Filter area ( m <sup>2</sup> )	16
Filter rate	>99%
Size of the working table (mm)	780*540*
Height of the working table (mm)	850
Dimension (mm)	800*1020*1720



Application

- Lithium battery slitting machine matching
- Composite material cutting machine matching
- CNC machine matching

## VJ Series Simple Type Industrial Dust Collector

APPLICATION:

- Dedust by matching with lithium battery slitting machine, composite material cutting machine, CNC machine and other bigger size dust.

SPECIALTY:

- 1、 Crosswise filter cartridge structure + water and oil proof filter cartridge
  - 1.1 Crosswise type installation can reduce the height of whole machine, and it is very suitable for using in space limited working condition.
  - 1.2 The material of filter cartridge can resist oil, water and stain, so the dust is not easy to adhere on the filter cartridge, but convenient to do the cleaning job.
  - 1.3 When need special cleaning, customer can open the rear door and clean the dust on the surface of filter cartridge by using pneumatic gun.



VJ Series

STRUCTURE DIAGRAM :

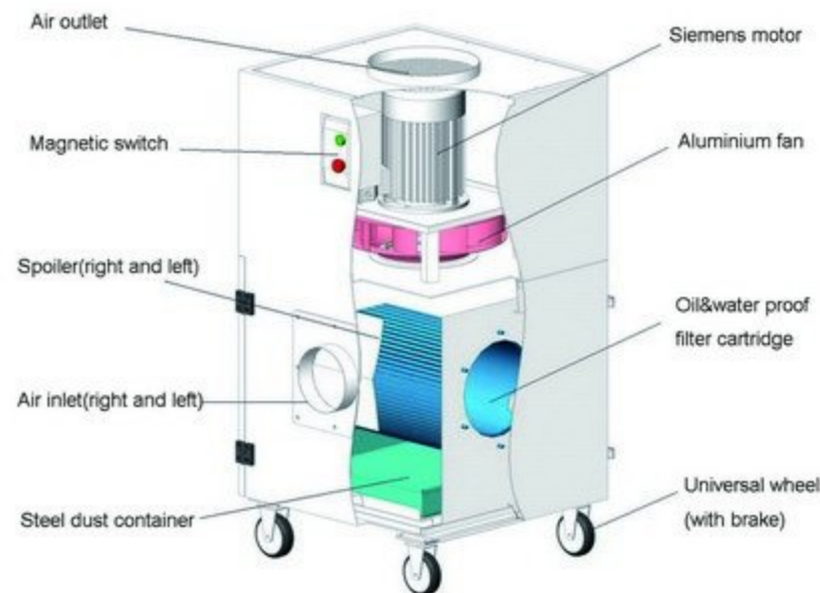

Crosswise filter cartridge structure

2、 Simple electronic-control structure, can achieve remote control

- 2.1 To protect the machine running safely and conveniently, the electronic-control components choose simple type magnetic switch which has thermal overload function. It can make sure the safety running for the machine. Also, it can achieve remote control function according to customer' s requirement.



Simple electronic-control structure

EXAMPLE FIGURE:

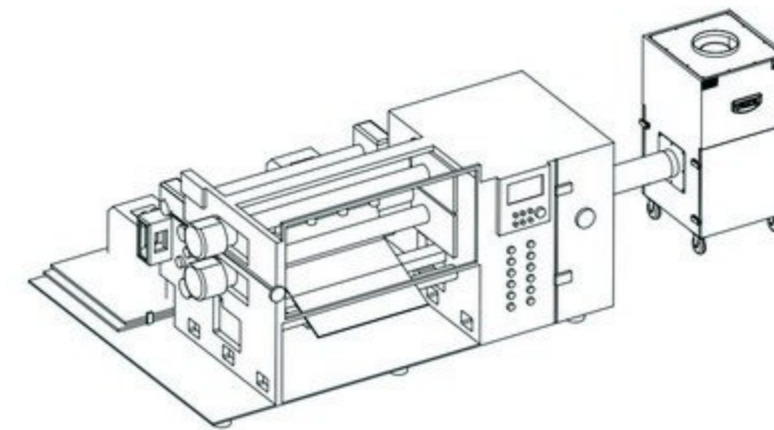

Lithium battery slitting machine matching

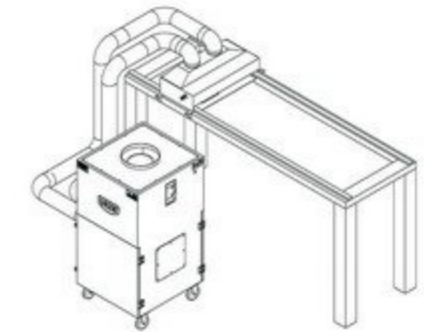

Dedust residual dust on glass plate

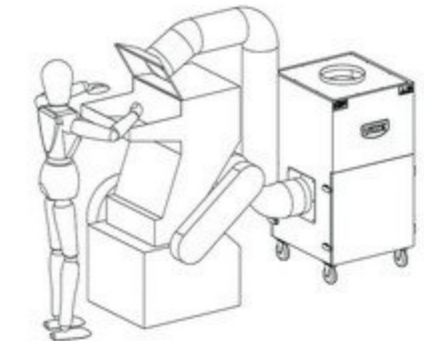

Crusher machine matching

TECHNICAL PARAMETERS:

Model	VJ-1.5	VJ-2.2	VJ-3.0	
Voltage (V/Hz)		380/50		
Power(Kw)	1.5	2.2	3.0	
Air pressure (Pa)	1200	1500	1800	
Max air flow(m <sup>3</sup> /h)	1800	2800	3600	
Noise dB(A)	75 ± 2		78 ± 2	
Air inlet (mm)	Ø150 (standard)		Ø200 (standard)	
Air outlet(mm)	Ø250 (standard)			
Filter unit	Filter area(m <sup>2</sup> )	8	16	
	Material	Water&oil proof ( standard ) or customized		
	Efficiency ( μ m )	3-5		
	Quantity(pcs)	1	1	2
	Cleaning way	Manual air gun dust cleaning		
Capacity of the dust container (L)	15	15	30 ( 2Pcs )	
Dimension (mm)	550*600*1130	625*600*1160	900*600*1310	
Power line (m)	4 ( 4cores )			
Mobility	Universal industrial wheel (with brake)			
Weight (kg)	120	130	180	
Protection level	Ip55	Ip55	Ip55	
Appearance spraying	Winkles white or customized			



- Application**
- Grinding operation
  - Vibration screen
  - Sandblasting operation
  - Packaging operation
  - General superfine dust mixing operation

## VJF Series Pulse Jet Cleaning Type Industrial Dust Collector

**APPLICATION:**

- Apply to grinding, sandblasting, mixing, packaging, vibration screen, material crushing and other operations about the general floating and superfine dust.

**SPECIALTY:**

### 1、Patented pulse jet cleaning device

1.1 Instead of the common straight nozzle on the market, Villo use the 90° spiral nozzle to improve the filter dust cleaning, the cleaning area can cover the whole filter cartridge almost after one time cleaning process and no dead zone exist. For now, this system and device have got 2 patent: Pulse jet cleaning system for the dust collector automatic dust cleaning system (Patent NO.: 201120435998.X) and one kind of spiral type pulse jet cleaning device (Patent NO.: 201120567339.1).



VJF Series



Pulse-jet structure

### 2、HEPA PTFE filter cartridge

- 2.1 TORAY base material HEPA PTFE filter cartridge, the filter rating can reach 99% for the 0.3µm size dust, the elimination for the PM2.5 is very well too.
- 2.2 Upright installation way, which is more space saving and can protect the filter away from the dust accumulation.
- 2.3 Spoiler installed at the air inlet place, so that the bigger size particle can drop into the dust container directly, and needless to install an additional cyclone device, too. Not only save the cost, also can lower the filtering air flow and enhance the filtering effect.



Filter cartridge structure

**STRUCTURE DIAGRAM:**

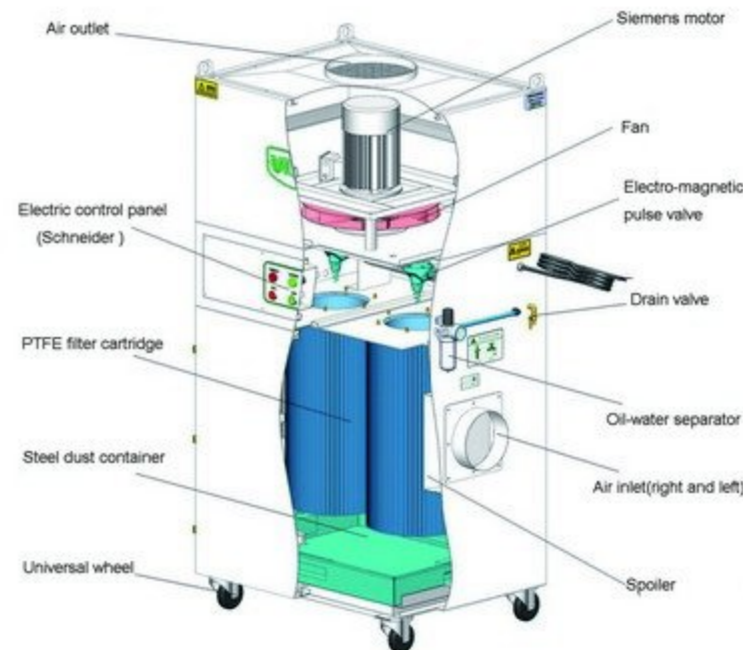

**SUCCESSFUL CASE :**



Steel pipe grinding supporting dust cleaning



Belt transshipment point dust cleaning



Feed mixing supporting dust cleaning



Rubber roller grinding supporting dust cleaning

**TECHNICAL PARAMETERS :**

Model	VJF-1.5	VJF-2.2	VJF-3.0	VJF-4.0	VJF-5.5	VJF-7.5	VJF-15
Voltage ( V/Hz )	380/50	380/50	380/50	380/50	380/50	380/50	380/50
Power ( Kw )	1.5	2.2	3.0	4.0	5.5	7.5	15
Air flow ( m³/h )	1800	2800	3600	4800	5800	5712—10562	7728—15455
Air pressure ( Pa )	1200	1500	1800	2000	2200	2554—1673	3187—2019
Filter cartridge quantity(pcs)	1	2	2	4	4	6	9
Filter area ( m² )	11	22	26	44	44	66	99
Filter rating ( µm )	0.3-1	0.3-1	0.3-1	0.3-1	0.3-1	0.3-1	0.3-1
Filter efficiency	99%	99%	99%	99%	99%	99%	99%
Filter material	PTFE from "TORAY" ,Japan						
Compressed air pressure(Mpa)	0.4-0.6	0.4-0.6	0.4-0.6	0.4-0.6	0.4-0.6	0.4-0.6	0.4-0.6
Cylinder capacity of the compressed air ( L/ pcs )	8	8	8	10	10	14	14 ( 2 pcs )
Capacity of the dust container ( L )	30	50	50	60 ( 2pcs )	60 ( 2pcs )	80 ( 2pcs )	100 ( 2pcs )
Noise(dB )	75 ± 2	77 ± 2	78 ± 2	82 ± 2	84 ± 2	86 ± 2	88 ± 2
Filter way	Negative pressure external filtration						
Dust cleaning way	Pulse jet cleaning+dust container						
Air inlet diameter ( mm )	Ø150	Ø150	Ø200	Ø250	Ø300	Ø350	Ø400
Air outlet diameter ( mm )	Ø250	Ø250	Ø250	Ø400	Ø400	Ø500	Ø500
Dimension (mm)	650*600*1736	900*700*1850	900*700*1850	1000*900*1950	1000*900*1950	1350*900*1985	1350*1250*2175
Power line (m)	4 ( 4cores )						
Weight (kg)	180	260	280	340	360	600	830
Mobility	universal industrial brake wheel			fixed foodstand			
Protection level	IP55	IP55	IP55	IP55	IP55	IP55	IP55
Appearance spraying	Winkles white or customized						