

**starmix**

“Pressures on!”

The new “4-all”  
Pump vacuum cleaner.



THE STARMIX HS PA-1455 KFG  
“4-ALL” PUMP VACUUM CLEANER



# The new "4-all" Pump vacuum cleaner: With integrated immersion pump. Perfect for sucking up dirty water!



## 1. Flat-roof refurbishment



**Vuum cleaner with integrated immersion pump  
For suction/pumping larger quantities of water.**

The Starmix "4-all" Pump vacuum cleaner has been developed especially for the suction of larger quantities of water and non-flammable liquids with a high level of contamination. Because of the appliance's high suction power, the liquid can be rapidly extracted until completely drained.

The robust and powerful pump built into the vacuum cleaner ensures that the container is permanently emptied during suction. Permanent pumping = permanent working.

A wet filter sack, which is included with the product, collects coarse dirt, protects the pump, and filters water which is only slightly dirty, if required. There is the possibility of attaching fire brigade C-connections.

## 2. Sanitary and heating installations



The vacuum cleaner is equipped with a powerful 1400 watt motor fan. The appliance is delivered with an extremely robust 55 l. stainless steel container with a convenient tilting running gear.

The Starmix Pump vacuum cleaner is also ideally suitable for the suction of residual water from heating systems and flooded buildings, and for cleaning swimming pools, tanks, etc.

**At the same time, the appliance is also a universally applicable wet and dry vacuum cleaner for the most varied areas of application.**

## 3. Removal of flood and residual water



Appliance socket with automatic ON/OFF-switch.

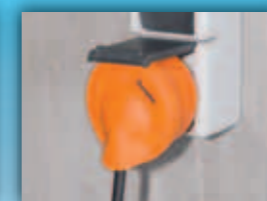

GFCI protection switch. Interrupts power supply when leakage currents occur.



Optional: GEKA-C connection.



Washable filter sack for filtering water.

## 4. Pond and pool cleaning



With the special accessories, the "4-all" Pump vacuum cleaner can also be used as a pond vacuum cleaner. Using an adjustable suction nozzle, dirt particles up to 10 mm in size, water weed, mud, and leaf residues can easily be extracted. These particles are gathered in the wet filter sack, and the cleaned water is continuously led off or returned to the pond.

As well as the applications described, this appliance can be used even without its pump and with various filter technologies as a universal multipurpose vacuum cleaner – a real appliance "4-all".



**Good, better, Starmix!**

## HS PA-1455 KFG "4-all" Pump vacuum cleaner

Order no. 18 72 28

### Features

- 55 l special stainless steel container with 2 carrying handles and metal seals
- tilting running gear
- carrying handle with practical cable and hose coil
- plug holder
- storage space for tools and small parts
- appliance socket with automatic ON/OFF switch
- speed control (2-level)
- gentle start control
- electronic after-running feature
- 8 metres, PVC power cable incl. ground fault circuit interrupter
- overflow protection
- antistatic prepared
- lockable, extendable suction hose
- hose holder
- polyester folded filter cartridge FPP 3600
- 1 x foam filter FSS 1200
- 1 x wet filter sack FSN 80

### Technical data

Power capacity max.	2200 Watt incl. pump
Volume flow max.	61 l/s
Vacuum max.	248 mbar
Container volume max.	55 l gross 50 l dust 43 l water
Dimensions (L x W x H)	59 x 57 x 100 cm
Weight	26.8 kg
Pumping capacity max.	300 l/min
Pumping capacity in suction mode max.	40 l/min
Suction height in full suction mode max. in slurp mode max.	1.5 m 5 to 8 m
Suction height from vacuum cleaner max.	6 m
Pumping distance max.	50 m

### Vacuum cleaner with built-in immersion pump. For suctioning greater quantities of water for:

- flat-roof refurbishment
- sanitary and heating installations
- cleaning ponds and pools
- eliminating flooding and residual water
- can also be used as a normal wet and dry vacuum cleaner



Protection class I Antistatic prepared

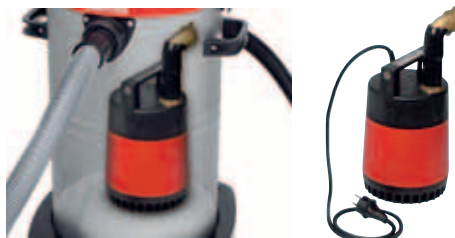

### Standard accessories for Pump vacuum cleaner

- 1 x suction hose (Ø 35 mm x 5 m)
- 1 x plastic tube handle with secondary air slide
- 2 x plastic suction tubes (each 50 cm)
- 1 x professional floor nozzle with brushes and rubber insert
- 1 x drain hose (Ø 33 mm x 5 m)



### Special accessories for TSZ Pond cleaning

- 1 x suction hose (Ø 49 mm x 5 m)
  - 1 x drain hose (Ø 33 mm x 10 m)
  - 4 x plastic suction tubes (each 48 cm, 1 x transparent)
  - 1 x large dirt nozzle
  - 1 x pond vacuum cleaner nozzle
  - 1 x 49 mm nozzle adapter on 35 mm hose system
  - 1 x wet filter sack FSN 1000
- The TSZ is supplied in a robust container box with 2 rolls.  
Dimensions: 800 x 400 x 320 mm, volume: 75 l, colour: blue

Complete set Order no. 19 37 00



You will find a further extensive range of accessories in our accessories list.

## The new 4-in-1 vacuum cleaner for universal use.

- Flood water vacuum cleaner
- Residual water vacuum cleaner for sanitation and heating construction
- Universal vacuum cleaner for dry and wet dirt
- Pool and pond vacuum cleaner

## Pumping capacity in combination with vacuum cleaner and pump

### Suction of contained water (100 % water)

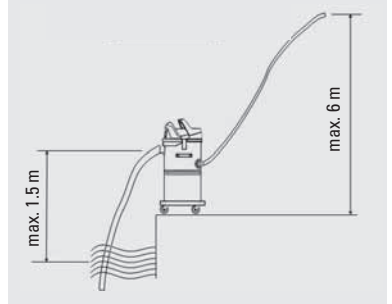

### Slurp mode (water/air mixture)

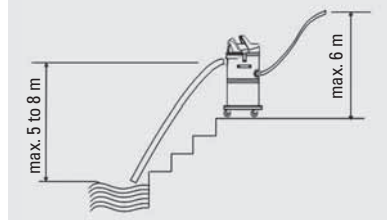

### Pumping distance

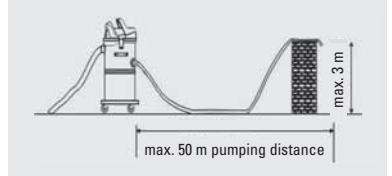

**ELECTROSTAR Schöttle GmbH & Co. KG**

P.O. Box 1240 · D-73259 Reichenbach/Fils · Germany

Phone +49(0)7153/982-0 · Fax +49(0)7153/982-348

E-Mail: [infoe@starmix.de](mailto:infoe@starmix.de) · [www.starmix.de](http://www.starmix.de) · bbn 40 11 24 08